

## **Guidelines for Display**

The following Guidelines for Display Rules and Regulations have been established for PAACE Automechanika Mexico. It is Messe Frankfurt's goal that the display rules and regulations, ultimately, shall provide exhibitors with all the information necessary to properly design and build exhibits, as well as plan their booth's layout and content.

**IMPORTANT: All exhibitors not using the standard booth package must submit their booth design to Show Management for approval. Exhibitors will not be allowed to move-in onsite without the approval of their booth design. Please complete the enclosed Booth Approval form to finalize your booth design and construction.**

July 13 – 15, 2011  
 Centro Banamex, Mexico City, Mexico

**Guidelines for Display**

**Linear / Corner Booths**

Linear Booths have only one side open to an aisle and are generally arranged in a series along a straight line. They are also called “in-line” booths. A Corner Booth is a Linear Booth exposed to aisles on two sides. All other guidelines for Linear Booths apply. Floor covering is required in all rented space.

**Dimensions**

Unless constricted by space or other limitations, Linear and Corner Booths are most commonly 3m (10ft) wide and 3m (10ft) deep, i.e. 3m x 3m (10ft x 10ft).

**Use of Space**

Messe Frankfurt Shows allow exhibitors full “Cubic Content” use of the exhibit space. Therefore, you are allowed to place displays or materials at the permitted height throughout the entire width and depth of your exhibit space. **A minimum of 36 sqm is required for any two-story display. All two-story displays must be approved in advance by Show Management.**

**Height Guidelines**

- Contracted space up to 9sqm are allowed 3m in height.
- Contracted space from 10 sqm to 35sqm are allowed 4m in height.
- Contracted space 36sqm and larger are allowed height up to 5.7m in height.

**Hanging Banners**

A minimum of 36 sqm is required for any **hanging** banners. Per building regulations, no hanging signs or banners can be hung any higher than 6m in Centro Banamex.

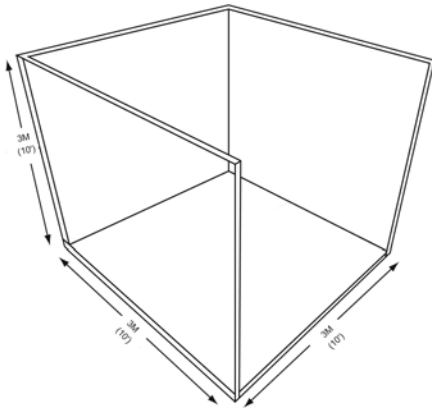

LINEAR BOOTH (3M x 3M)

**9 SQM**

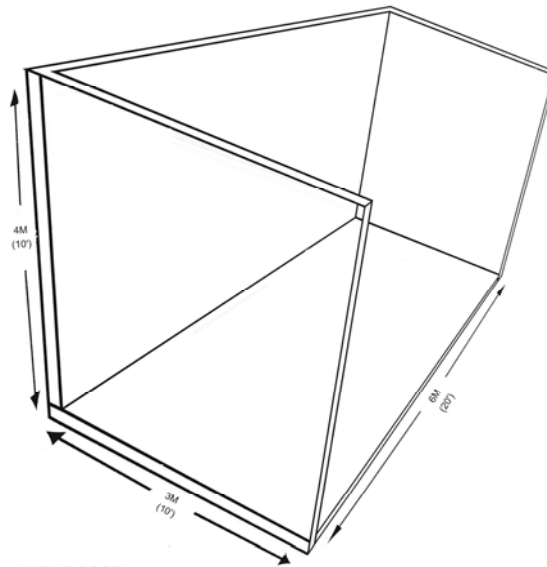

LINEAR BOOTH (3M x 6M)

**18 SQM**

July 13 – 15, 2011  
Centro Banamex, Mexico City, Mexico

## Guidelines for Display Cont.

### Peninsula Booth

A Peninsula Booth is exposed to aisles on three (3) sides and is a minimum of 6m x 6m (20' x 20') or 36sqm in size. Floor covering is required in all rented space.

### Dimensions

A Peninsula Booth is 36sqm (400sq ft) or larger.

### Use of Space

The maximum height allowed throughout the booth space is 5.7m (18.5ft). The connecting wall between the peninsula booth and any neighbors must be "finished off" (clean and presentable to visitors) on the side facing the connecting neighbors. **A minimum of 36 sqm is required for any two-story display. All two-story displays must be approved in advance by Show Management.**

### Height Guidelines

- Contracted space up to 9sqm are allowed 3m in height.
- Contracted space from 10 sqm to 35sqm are allowed 4m in height.
- Contracted space 36sqm and larger are allowed height up to 5.7m in height.

### Hanging Banners

A minimum of 36 sqm is required for any **hanging** banners. Per building regulations, no hanging signs or banners can be hung any higher than 6m in Centro Banamex.

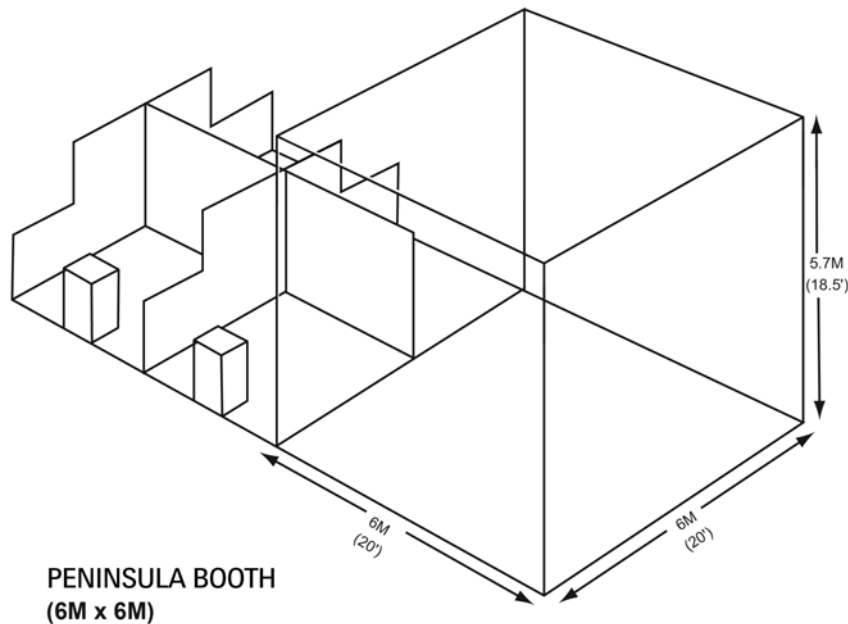

**36 SQM**

July 13 – 15, 2011  
Centro Banamex, Mexico City, Mexico

## **Guidelines for Display Cont.**

### **Island Booth**

An Island Booth is any size booth exposed to aisles on all four sides, and is a minimum of 6m x 6m (20' x 20') or 36sqm in size. Floor covering is required in all rented space.

### **Dimensions**

An Island Booth is 36sqm (400sq ft) or larger.

### **Use of Space**

The maximum allowable height allowed throughout the booth space is 5.7m (18.5 ft). **A minimum of 36 sqm is required for any two-story display. All two-story displays must be approved in advance by Show Management.**

### **Height Guidelines**

- Contracted space up to 9sqm are allowed 3m in height.
- Contracted space from 10 sqm to 35sqm are allowed 4m in height.
- Contracted space 36sqm and larger are allowed height up to 5.7m in height.

### **Hanging Banners**

A minimum of 36 sqm is required for any **hanging** banners. Per building regulations, no hanging signs or banners can be hung any higher than 6m in Centro Banamex.

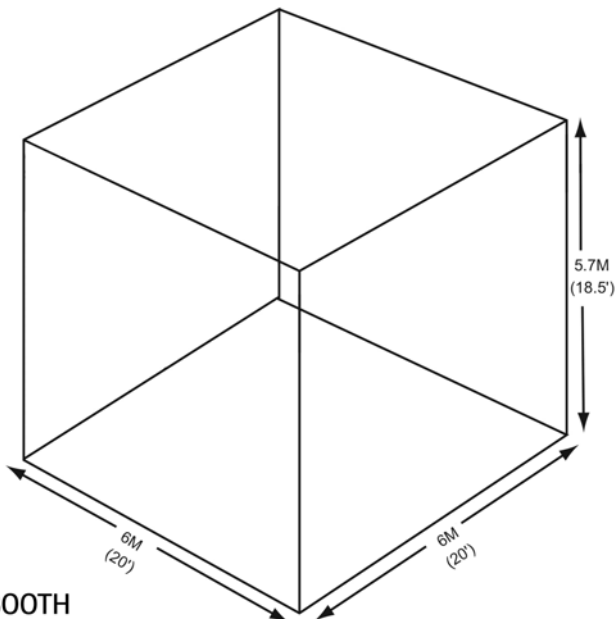

**ISLAND BOOTH**  
**(6M x 6M)**  
**36 SQM**

July 13 – 15, 2011  
Centro Banamex, Mexico City, Mexico

## **Rules & Regulations**

**MANAGEMENT:** The Event will be conducted under the direction of PAACE Automechanika Mexico, LLC, 1600 Parkwood Circle, Suite 615, Atlanta, Georgia; designated as “Management” in this document. An “Exhibitor” is an applicant that has been accepted for participation in the Event by Management. Acceptance of an Exhibitor shall be in written confirmation. The issuance of a Booth confirmation notice, in response to a submitted Exhibitor Contract, shall conclude the contact of participation between Management and the Exhibitor. The Exhibitor and Management acknowledge these Event Terms and Conditions as the elements of the contract of participation. Violations of any of the Event Terms and Conditions of the contract shall entitle Management to exclude an Exhibitor from the Event and seek remedies for damages caused by such violations. The Exhibitor must comply with the Event Terms and Conditions relating to the officially designated show contractors.

**CONDITIONS OF PAYMENT:** Any dispute by Exhibitor with any exhibition event services provided by Management or any affiliate, or the amount charged for the same shall be reported to Management in writing within 15 days from the date of invoice relating to same, time being of the essence (but such dispute shall not affect Exhibitors obligation to make payment within 15 days as set forth below). Failure to report any such dispute within such time shall constitute a waiver of any claim by Exhibitor with respect to such dispute. Whether sums are due under contract or open account, it is understood that all invoices are due upon receipt and are considered delinquent if not paid within 15 days from the date of invoice or the date as indicated on the invoice. Should timely payments not be made as stated, Exhibitor agrees to pay all collection agency fees and expenses, and other costs of collection, including reasonable attorney fees and court costs which may be incurred by Management or any affiliate in pursuing and collecting payment. The liability of Exhibitor shall be joint and several with Third Parties. The party executing this agreement on behalf of Exhibitor acknowledges that it has the authority to do so and that by its execution it has caused Exhibitor and Third Parties to be jointly and severally bound by the terms hereof. Exhibitor represents that Third Parties will immediately be notified of the terms hereof. Notwithstanding to whom bills are rendered, Exhibitor and Third Parties shall remain jointly and severally obligated to pay to Management the amount of any bills rendered by Management within the time specified and until payment in full is received by Management. Payment by Exhibitor to Third Parties or by Third Parties to Exhibitor shall not constitute payment to Management.

**USE OF EXHIBIT SPACE:** The Exhibitor contracts to use the booth for the duration of the Event in conformity with Management’s guidelines. Management has the right to relocate a booth at its discretion. The Exhibitor and its representatives shall conduct themselves in a business-like manner. In cases of disruptive and unprofessional behavior, exhibitor has the right to ask disruptive individuals to leave its booth. Show management reserves the right to revoke trade show participation privileges from such individuals. Exhibits may not obstruct overall view or hide the exhibits of others. Unusual or specially built booths must have Management approval. Management reserves the right to restrict or remove exhibits that are distracting or distract from the character of the Event. Booths must be set up prior to the opening of the Event. Management has the right to re-allocate a booth at its discretion if the Exhibitor has not appeared or begun to set up by 6:00 p.m. on the day previous to the opening of the Event. The Exhibitor will assume the cost of any additional services/equipment required for their respective exhibit space. Exhibitors shall not assign, sublet, share or apportion the whole or any part of the space allotted, or have representatives, products, equipment, signs or printed materials from other than its own firm contracted in the assigned exhibit space without the prior written consent of Show Management. All Exhibitors must comply with the enclosed Guidelines for Display. Failure to comply with the rules will result in the exhibitor being required to pay a penalty fee equal to the amount of the deposit in the exhibit space application. Any booth construction requires the prior written approval of Management. No two-story displays will be approved for areas under 36 square meters. Any logo, picture or promotional elements must be placed within the limits of the Exhibitor’s booth. In addition, projecting and/or directing images, lighting or sound outwards from the booth is prohibited. All back walls must be finished.

July 13 – 15, 2011  
Centro Banamex, Mexico City, Mexico

## **Rules & Regulations Cont.**

**HEIGHTS:** As specified in the Guidelines for Display, the maximum height regulations are as follows:

Areas up to 9 square meters:	3 meters high
Areas from 10 square meters to 35 square meters:	4 meters high
Areas from 36 square meters and up:	5.7 meters high

No two-story displays will be approved for areas under 36 square meters.

A minimum of 36 sqm is required for any **hanging** banners. Per building regulations, no hanging signs or banners can be hung any higher than 6m in Centro Banamex.

**BOOTH PACKAGE:** Each 9 sqm booth rented under the package rate will include booth construction, company signage, carpet (show color), (1) table, (2) chairs, (1) electrical outlet, lighting and (3) booth personnel badges.

**RAW SPACE:** Booths rented under the raw space rate will not come with construction, carpet, furnishings or electricity.

**BOOTH RESPONSIBILITY:** It will be the responsibility of the company who contracts the space to maintain personnel in the booth at all times during the show hours. Any Exhibitor who starts to pack or dismantle their booth prior to the show closing will be charged a fee of \$1,000 and may forfeit any seniority to future shows.

**AUDIO AND SOUND:** The use of sound systems is permissible provided the sound is not more than 70 decibels at three meters from the source of emission. Management has absolute control over sounds regulations. If Exhibitors do not respect the sound regulations set forth by Management during the show, electric power to the Exhibitor's stand will be suspended for the day. With authorization from Management, each exhibitor will have the right to one show, with a maximum duration of five minutes every two hours.

**EVENT SCHEDULE:** Construction and dismantling hours must be adhered to unless written approval is received from Management.

**SALES ACTIVITIES:** All retail sales activities must have written approval by Management; any royalties or commissions resulting from sales activity must conform with the Event Terms and Conditions.

**PHOTOGRAPHY:** Management has permission to use the likeness of any person and/or products exhibited in photographs and in any and all other media, whether now known or hereafter existing. The exhibitor waives the right to inspect or approve the finished product, including written or electronic copy. Additionally, all rights to royalties or other compensation arising or related to use of the photograph are waived by the Exhibitor.

July 13 – 15, 2011  
Centro Banamex, Mexico City, Mexico

## **Rules & Regulations Cont.**

**PROMOTION AND GIVEAWAYS:** All exhibitor promotional material and goods are limited to the designated display area. Booth giveaways are permissible provided they are located in an area such that any crowd that gathers will be contained within that exhibitor's space and will not block the aisles or neighboring exhibits. If you intend to conduct any activity that will attract a large number of attendees to your booth, you must purchase enough booth space and orient your booth structures so that the crowd can be accommodated within your booth space and at a maximum, 5 feet into the adjacent aisle. Management reserves the right to cease any publicity/presentations that have not been approved and do not meet the standards of the Event.

**MEDIA AND PRESS RELATIONS:** Any activities conducted by the media whether arranged by the Exhibitor or separately shall be conducted through the Management Press Office.

**EXCLUSION OF LIABILITY:** Management shall not be liable to an Exhibitor for damages caused by Acts of God, war, civil disturbances, fire, violence, building malfunction, inclement weather or any other circumstances beyond the control of Management, including damage caused by visitors to the Event, other Exhibitors or persons acting on their behalf. In addition, Management shall not be liable for the number of visitors or sales generated from participation.

**SECURITY AND LIABILITY:** All local, state and federal laws shall be observed during the Event in the exhibition area. The Exhibitor shall observe all safety regulations of the facility, directives by security personnel and Management personnel. The Exhibitor shall be liable for all damage to persons or property, economic losses which have been caused by booth construction, booth equipment, exhibits and any employees acting on its behalf. The Exhibitor shall obtain all required permits prior to the commencement of the Event and have them available for inspection by Management. Management will provide Security during the construction of and dismantling times as well as throughout the duration of the Event, but will not be liable for the loss or damage of any exhibitor property. **No one under the age of 18 will be permitted on the show floor at any time.**

**INSURANCE:** The Exhibitor is responsible to provide sufficient insurance protection.

**PREVENTION:** The Exhibitor shall not use any flammable decorations or coverings for display purpose. All fabrics or other material used for decoration purposes shall be flameproof. The Exhibitor shall comply with all applicable fire regulations.

**BOOTH DISMANTLE:** The exhibition area is to be returned by the Exhibitor in the same condition as it was handed over. In the case of any damage to the exhibition area or the halls (structure, floor, cables, ducts, etc.), it shall be repaired at the Exhibitor's expense. If the clearance of the booth has not been undertaken in good time, Management may have it cleared and the goods put in storage at the expense of the Exhibitor. Management shall assume no liability for exhibits left behind.

**COMMERCIAL TRADEMARK AND OTHER COMMERCIAL RIGHTS:** Management expects exhibitors to honor commercial trademarks and other commercial rights. In case of documented trademark or other commercial right infringements, Management reserves the right to exclude an exhibitor from the current and future events. This stipulation does not create an obligation for Management to take such action. Management does not accept any liability for commercial rights infringements that may be committed by an exhibitor.